



Type	Nom.Towing Pull (kN)	B1	B2	ØD	H1	H2	H3	L1	L2	S1	W1	W2	Weight (kg) DIN 1683-GTB18 (GS)
1	10	250	175	30	160	65	20	285	115	10	125	90	Ca.18 + 2 Horn 1,5
2	20	315	225	35	200	70	25	360	125	12	160	115	Ca.26 + 2 Horn 2
3	30	390	275	40	250	75	32	450	140	14	200	140	Ca.42 + 2 Horn 3
5	50	480	340	45	300	80	38	550	160	16	250	180	Ca.74 + 2 Horn 4
8	80	585	415	50	360	90	45	680	180	18	320	225	Ca.120 + 2 Horn 6
12	120	710	500	-	440	110	55	840	-	20	400	270	Ca.185
20	200	840	595	-	520	130	65	1020	-	22	500	320	Ca.285
32	320	1100	800	-	700	150	80	1300	-	35	600	400	Ca.795

Name	Material : GS-38.3-DIN-1681			Tolerance : DIN-81915			
	Drawn : HDG	Date : 9-3-2010	Checked : JDR	Date : 9-3-2010			
REV DATE	 SEA PARTS V.O.F. 9611TH Sappemeer Molenraai 11 The Netherlands T : +31 (0) 598 361 665 F : +31 (0) 848 375 685 W : www.seaparts.nl e: info@seaparts.nl			Description :			 A4
				MUTIPURPOSE-CHOCKS TYPE-A&B			

This drawing and design is protected by copyright and the information is confidential. It is also protected and registered under Dutch laws through the Dutch government department for Taxes. The drawing and/or models may not be copied, reproduced, duplicated or disclosed to others, in whole or in part without prior written consent of SEA PARTS V.O.F. / the Netherlands.

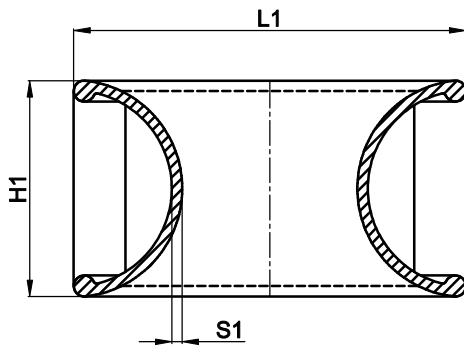
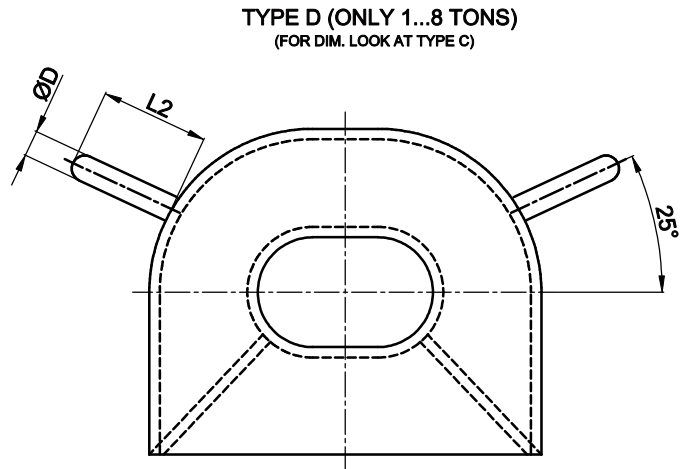
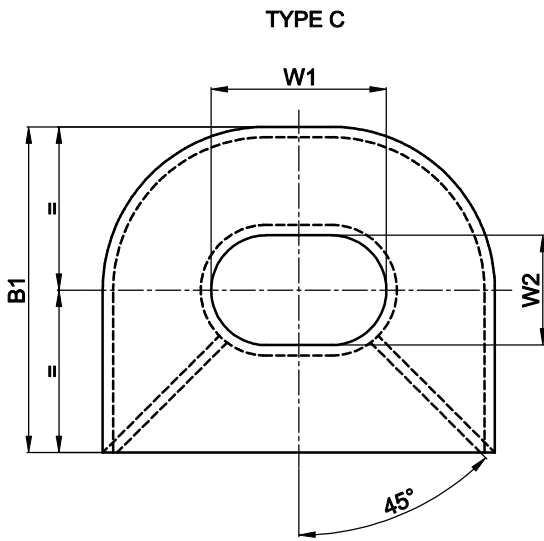

Type	Nom. Towing Pull (kN)	B1	ØD	H1	L1	L2	S1	W1	W2	Weight (kg) DIN 1683-GTB18 (GS)
1	10	250	30	160	285	115	10	125	90	Ca.19,5 + 2 Horn 1,5
2	20	315	35	200	360	125	12	160	115	Ca.29 + 2 Horn 2
3	30	390	40	250	450	140	14	200	140	Ca.48 + 2 Horn 3
5	50	480	45	300	550	160	16	250	180	Ca.85 + 2 Horn 4
8	80	585	50	360	680	180	18	320	225	Ca.136 + 2 Horn 6
12	120	710	-	440	840	-	20	400	270	Ca.211
20	200	840	-	520	1020	-	22	500	320	Ca.325
32	320	1100	-	700	1300	-	35	600	400	Ca.840

REV DATE	Name	Material : GS-38.3-DIN-1681		Tolerance : DIN-81915	
	Drawn : HDG	Date : 9-3-2010	Checked : JDR	Date : 9-3-2010	
SEA PARTS	SEA PARTS V.O.F.				Description : MULTIPURPOSE-CHOCKS TYPE-C&D
	Molenraal 11 T : +31 (0) 598 361 665 W : www.seaparts.nl		9611TH Sappemeer The Netherlands F : +31 (0) 848 375 685 e: info@seaparts.nl		
		Drawing no : CHOCKS-TYPE-C&D			A4 Size in mm Page : 1 / 1